

- Pellets
- Extruded Snacks/ Nik Naks
- Indian Ethnic Snacks
- Corn & Potato Chips
- Nuts & Mixes
- QSR/RTE/RTC/PRE MIX
- Convenience Food





GLOBAL PRESENCE



SOME OF OUR REGULAR PATRONS:



& MANY MANY MORE...





Welcome to Fabcon India

Hello (नमस्ते),

Since 1981, we are in business of providing Solutions for Snack & Food Industry. We Specialize in Customized Processing & Packaging Solutions & pride ourselves in delivering the best results by helping customer Go Live & realize their R.O.I within the defined budget & time line.

We master customization from Pre-Processing to Post-Packaging Solutions. We have been regularly meeting the diverse requirements of all our customers & have been regularly working with the Top Snack Manufacturers & OEM Companies in the Food & FMCG segment.

We are based out of Delhi NCR, India. Our setup is established over 100,000 square feet & has a motivated team of 150+ members. Our manufacturing facility is equipped with latest engineering technologies like Laser Cutting, CNC forming, CNC Machining, GBB finishing & proper PDI area for Quality Assurance & Packing.

We have supplied & successfully commissioned multiple processing lines all over India & overseas. Our customers are a testament of our quality & services. We are already exporting to over more than 50 Countries including US, Canada, UK, Australia (APAC), Gulf & Africa (MENA). Our equipment are CE / CSA / ULC / SASO compliant & adhere to GMP to ensure Food Hygiene & EHS.

We sincerely hope to work with you & look forward to discuss your current & future requirements & address them to your full satisfaction.

Kind regards (सादर धन्यवाद),

Please visit us at www.fabcon-india.com for more information on us.

-  :- <https://www.youtube.com/channel/UCfhyL-2JXroODzI8wzk-5-A>
-  :- <https://www.linkedin.com/company/fabcon-group-of-companies>
-  :- <https://www.facebook.com/official.fabconindia>
-  :- <https://twitter.com/NoidaFabcon>
-  :- +91-8510077831 / 32 / 33 / 34

We advocate : #MakeinIndia #Makelocalglobal #Farmtofork #HealthySnacking





WE PROCESS BETTER!



ENDLESS CHOICES....





1. Low Oil Volume as compared to industry standards
2. Quick O.T.T. ensures longer product life as oil remains healthy longer.
3. Customized Solutions
 - Choice of capacity
 - Choice of seasoning
 - Choice of heating source
4. 1 Fryer: Multiple Seasoning Stations
5. Capacities: 100-2000 kgh
6. Suitable for Snacks like Kurkure, Pellets etc
7. Heating Source: Electric / Gas / Diesel / TF
8. GMP based design: Hygienic & 100% washdown
9. Food safety orientation with no residue areas
10. CE & UL certified electrical & electronic components*
11. 100% Laser Cut and CNC sheet metal fabrication



SNACK FRY 'N' FLAV LINE



S.No.	DESCRIPTION
1	MEAL MIXER
2	BUCKET ELEVATOR FOR MEAL DISTRIBUTION
3	EXTRUDER
4	COLLECTION BELT CONVEYOR
5	NUBIN SEPERATOR FOR FINES REMOVAL
6	VIBRATORY FEEDER FOR CONTROLLED FEED
7	FRYER AND ACCESSORIES
8	DE-OILING CONVEYOR
9	VIBRATORY FEEDER FOR CONTROLLED FEED
10	FLAVOUR SCREW FEEDER
11	SCARF FEEDER FOR WIDER SPICE DISTRIBUTION
12	SLURRY SYSTEM
13	FLAVOURING DRUM FOR FLAVOUR COATING
14	TRANSFER CONVEYOR
15	BUCKET ELEVATOR SYSTEM FOR DISTRIBUTION

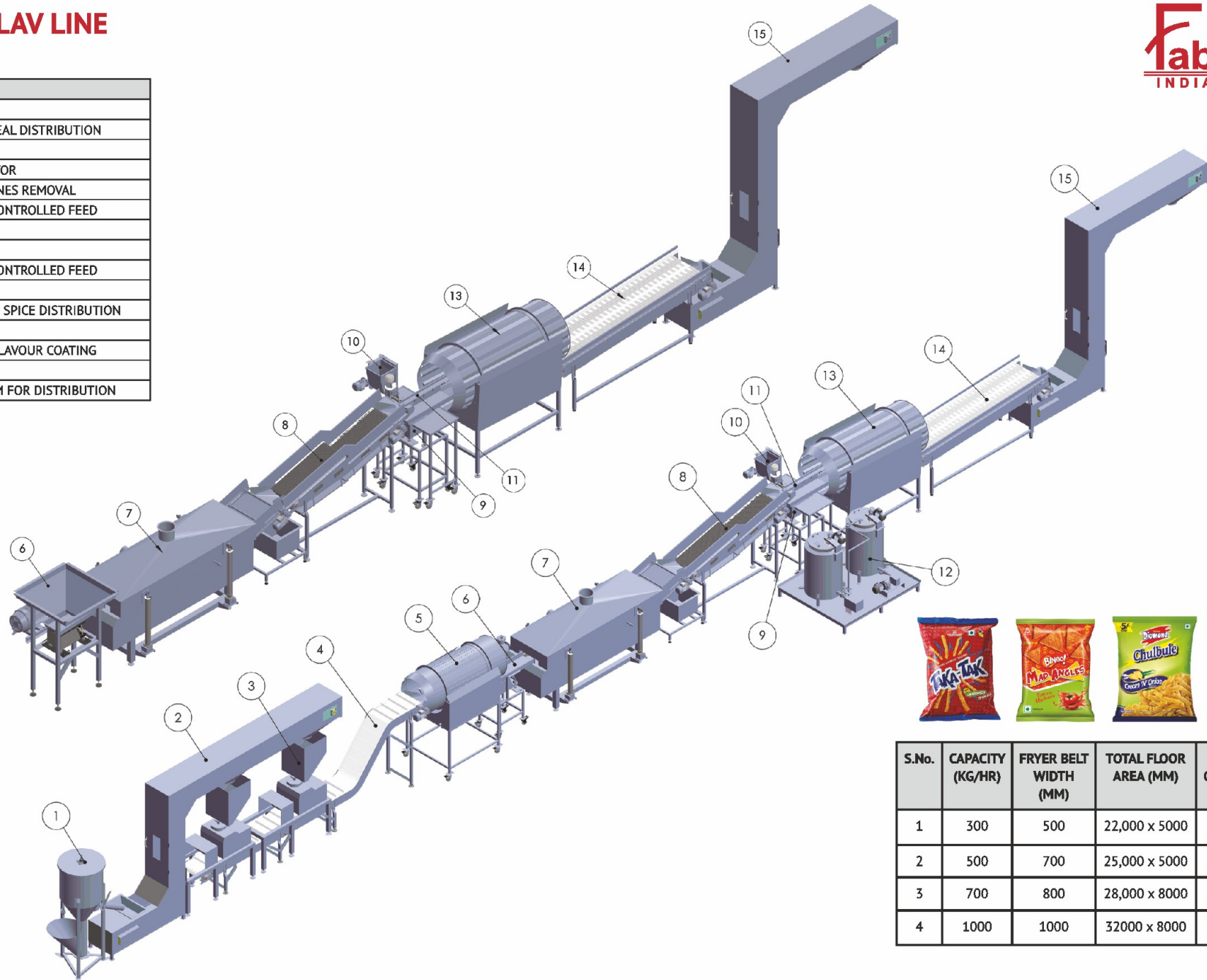

PELLETS PROCESSING LINE

EXTRUDED SNACK LINE



S.No.	CAPACITY (KG/HR)	FRYER BELT WIDTH (MM)	TOTAL FLOOR AREA (MM)	POWER CONSUMPTION (KW)
1	300	500	22,000 x 5000	24 KW
2	500	700	25,000 x 5000	30 KW
3	700	800	28,000 x 8000	32 KW
4	1000	1000	32000 x 8000	35 KW



SNACK PELLET FRY'N'COAT LINE



1. Capacities: 200-2000 kgh
2. Quick Frying Time of 8-30 seconds
3. Very Low Oil Volume: longer product shelf life
4. Oil Turnover ratio/time of about ~ 3-3.5
5. Heating Source: Electric / Gas / Diesel / TF
6. Small Foot Print: Full Line Size within 25 feet*
7. 1 Fryer: Multiple Seasoning Stations*
8. Fryer also suitable for Cheetos type Extruded products
9. GMP based design: Hygienic & 100% washdown
10. Food safety orientation with no residue areas
11. CE & UL certified electrical & electronic components*
12. 100% Laser Cut and CNC sheet metal fabrication



BAKED SNACKS LINE

EXTRUDED SNACKS HEALTHY & TASTY



S.No.	DESCRIPTION
1	MEAL MIXER
2	BUCKET ELEVATOR MEAL DISTRIBUTION
3	EXTRUDER
4	COLLECTION CONVEYOR
5	NUBIN SEPERATOR FOR FINES REMOVAL
6	VIBRATORY FEEDER FOR CONTROLLED FEED
7	DRYER SYSTEM (GAS/ELECTRIC)
8	PRODUCT TRANSFER CONVEYOR
9	VIBRATORY FEEDER FOR CONTROLLED FEED
10	SLURRY SYSTEM
11	FLAVOURING DRUM FOR FLAVOUR COATING

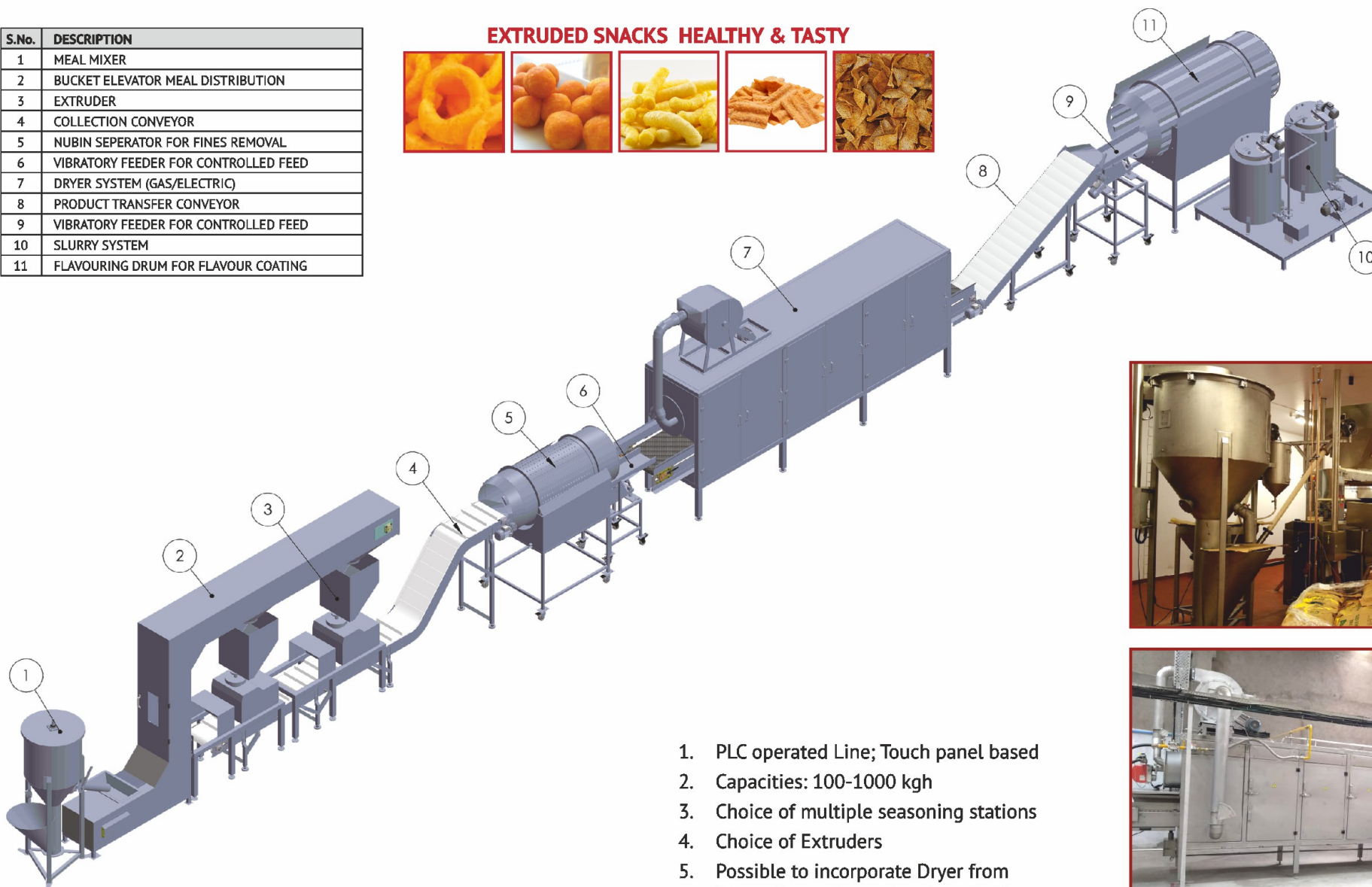

1. PLC operated Line; Touch panel based
2. Capacities: 100-1000 kgh
3. Choice of multiple seasoning stations
4. Choice of Extruders
5. Possible to incorporate Dryer from Planet Dryer, Seasoning from KMG



NAMKEEN PROCESSING LINE



1. Capacities: 200-2000 kgh
2. Suitable for:
Floating Besan based items like: Bhujia, Sev, Gathia, Boondi, Chevda, etc.
Non Floating items like: Peanut, Nuts, Coated Nuts, Dal/Pulses, Matar, Formed snacks etc.
3. Heating Source: Gas / Diesel / TF
4. Very Low Oil Volume: longer product shelf life
5. Oil Turnover ratio/time of about ~ 2.5-4
6. Heating Source: Electric / Gas / Diesel / TF
7. GMP based design: Hygienic & 100% washdown
8. Food safety orientation with no residue areas
9. CE & UL certified electrical & electronic components*
10. 100% Laser Cut and CNC sheet metal fabrication



NAMKEEN PROCESSING LINE



S.No.	DESCRIPTION
1	DOUGH EXTRUDER
2	PRE-FRYER
3	FRYER AND ACCESSORIES
4	AMBIENT AIR AFTER COOLER
5	VIBRATORY FEEDER CONTROLLED FEED
6	FLAVOUR SCREW FEEDER
7	SCARF FEEDER FOR WIDER SPICE DISTRIBUTION
8	FLAVOURING DRUM FOR PRODUCT MIXING WITH SPICE

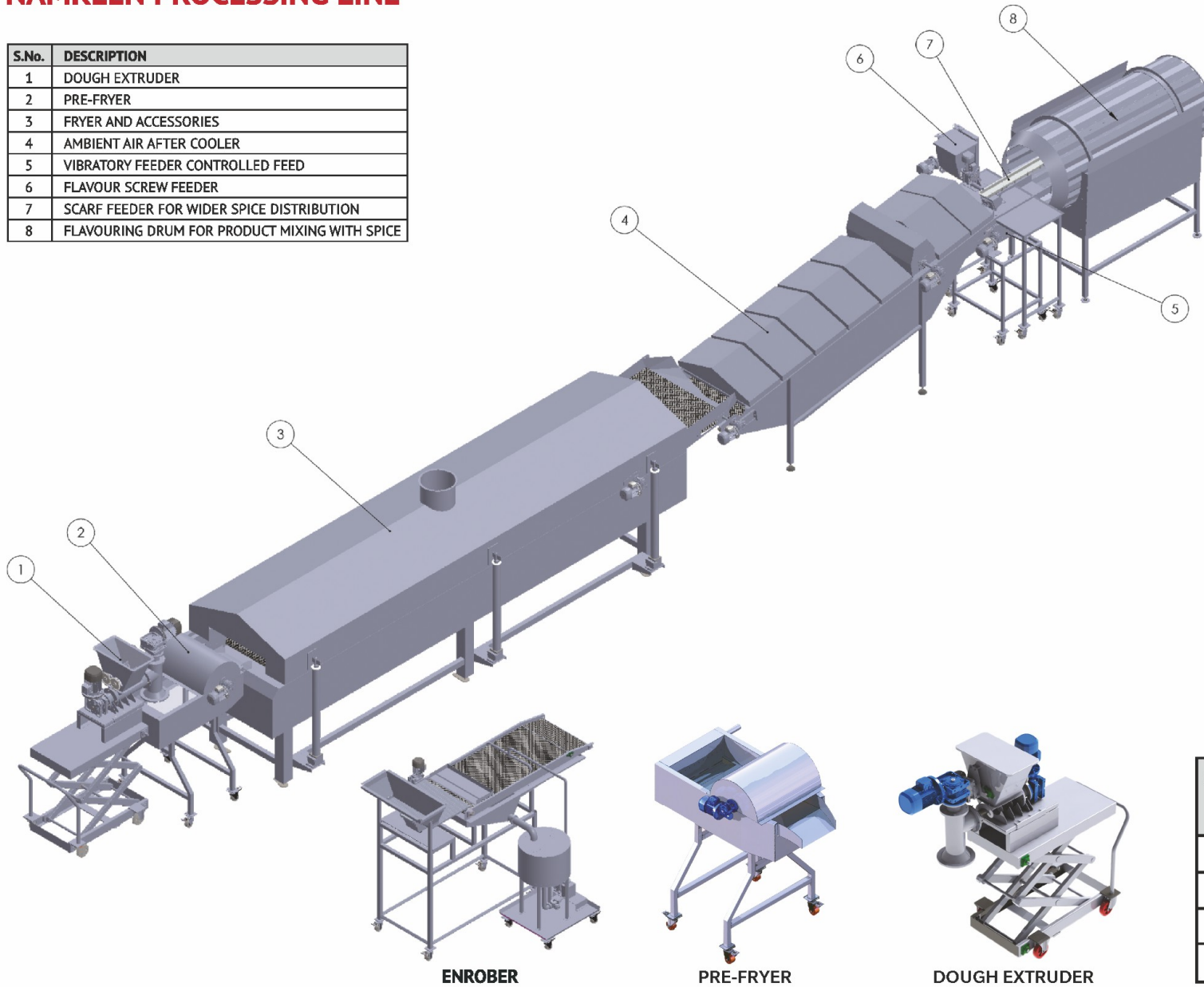

Suitable for multiple attachments like:

- a. Dough Extruder
- b. External Detachable Flume/ Pre – Fryer
- c. Enrobing System
- d. Feeding Vibratory Hopper

S.No.	CAPACITY (KG/HR)	FRYER BELT WIDTH (MM)	TOTAL FLOOR AREA (MM)	POWER CONSUMPTION (KW)
1	300	500	14,000 x 5000	14 KW
2	500	700	14,000 x 5000	18 KW
3	700	800	16,000 x 7000	20 KW
4	1000	1000	16000 x 7000	22 KW



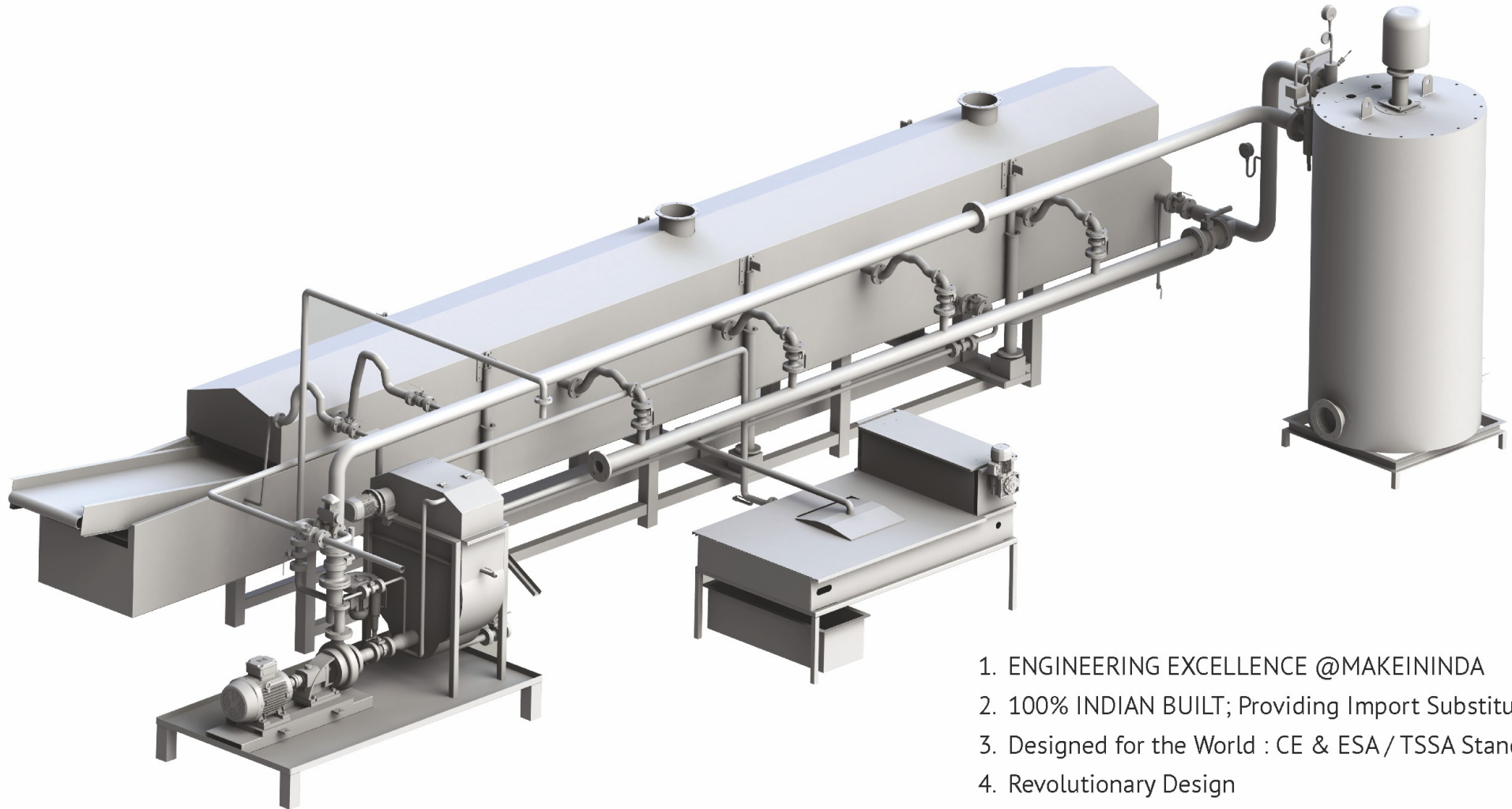

1. ENGINEERING EXCELLENCE @MAKEININDA
2. 100% INDIAN BUILT; Providing Import Substitution
3. Designed for the World : CE & ESA / TSSA Standards
4. Revolutionary Design
5. Incredibly low Oil Capacity
6. Multi Product Capability



CONTINUOUS FRYER FOR CONVENIENCE FOOD/ QSR

Features:

- Precise Temperature Control.
- Efficient Oil Management.
- Designed to optimize productivity and enhance product quality across various food applications.
- Superior Efficiency and Productivity.



Battering Station



Breading Applicator



KETTLE CHIPS

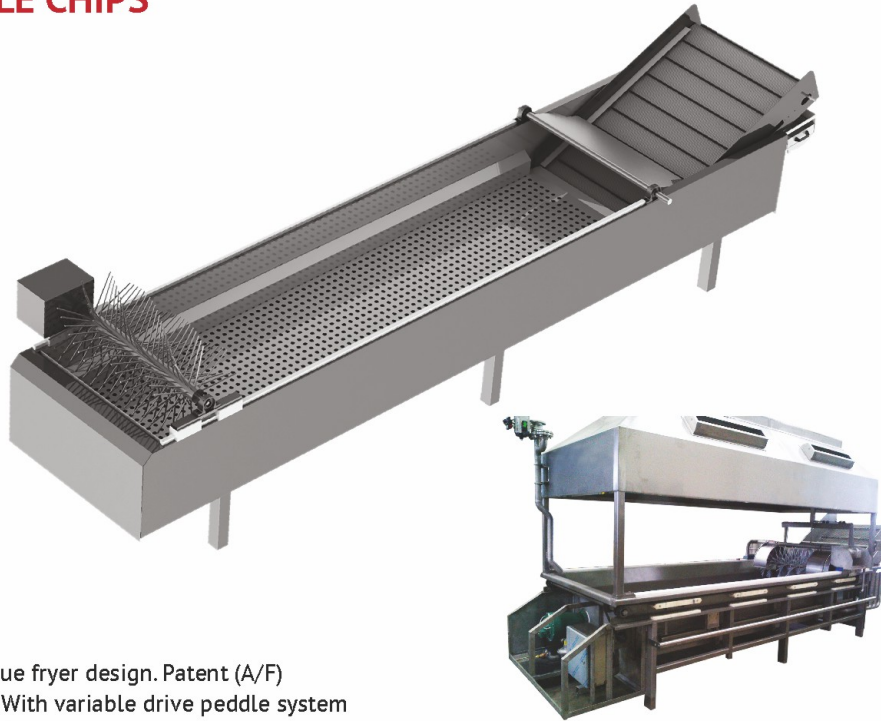

1. Unique fryer design. Patent (A/F)
 - a. With variable drive peddle system & gate
2. Best combination of automation in a traditional kettle (batch) style
3. Suitable low temperature & long frying time combination
4. Reduces oil pickup
5. Cost economic
6. Modular design; multiple units can be added to add capacity
7. Hybrid design: can attached to existing PC lines
8. Best suited for chips of
 - a. Potato
 - b. Casava
 - c. Vegetables
 - d. Indian traditional savories
 - e. Etc



TORTILLA CHIPS/ NACHOS

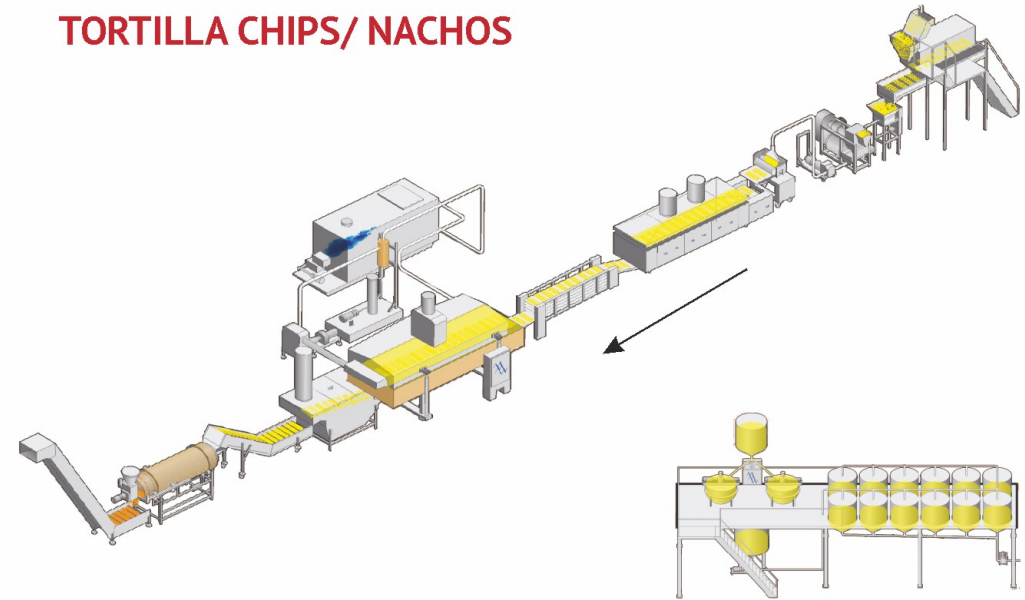

1. Unique fryer design. Patent (A/F)
 - a. With variable drive peddle system
2. Suitable sheeted / die cut snacks like tortilla, etc
3. Options of using whole corn to make Massa or use Massa flour
4. Hybrid design: can be used for making other extruded snacks
5. Line configuration can be optimized to meet requirements



CONTI - MIX SYSTEM



Trail Mix/ Muesli/
Granola Mix



Nut Mixture



Bombay Mix



Chana Chur Mix



Automatic Weigh Based Continuous Ingredient Mixing

1. Recipe Management System
2. Load Cell Based PLC System
3. Easy to Operate & Clean
4. Highly Accurate
5. CE & UL Certified
6. Zero Man Involvement
7. Hygenic & 100% Washdown
8. Cost Saving & Quick R.O.I.



Key Features:

- Designed for the perfect coating.
- Choice of Multiple Drum Profiles & Size to suit all product varieties

Options of:

- 1 Dry Seasoning only
 - 2 Slurry based application
 - 3 Oil Mist & Dry Dosing together
- **Capacities:** Varying per product 100-3000 kgh
 - **Best suited for:** Pellets, Extruded, Nuts, Indian Noodles, Sev, Namkeen, Bhujia, Mixes.
 - **NOW WITH:** DYNAMIC CLOSE LOOP WEIGHT BASED SEASONING CONTROLS



DYNAMIC WEIGH BASED SEASONING SYSTEM

Features :

- Ensures Compliance
- Calibrated Seasoning
- Consistent Product Coating
- Prevents Seasoning Loss
- Prevents Product Breakage
- Easy to Clean

Best For:

- Chips
- Extruded Snacks
- Pellets
- Nuts
- Trail Mixes

Capacity : 50 Kg to 3000 KGPH



RAW MATERIAL



Automatic Weigh Based
Conveying, Storage & Processing



FDA Certified Thermdrive Sidewall
GooseNeck Conveyor for Process Line



Flexible Screw Conveyor for Meal Distribution
for Snack Extruder

IN PROCESS



Ambient Air After-Cooler

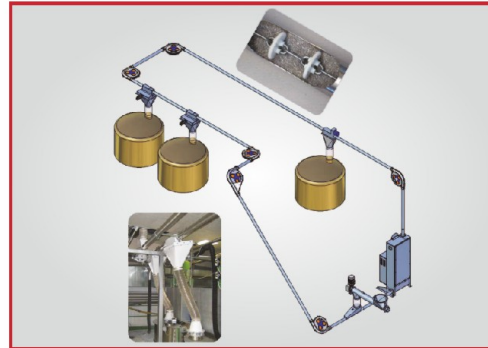

Bulk Conveying using Drag
(Chain/Rope-Disc) Conveyor for Process

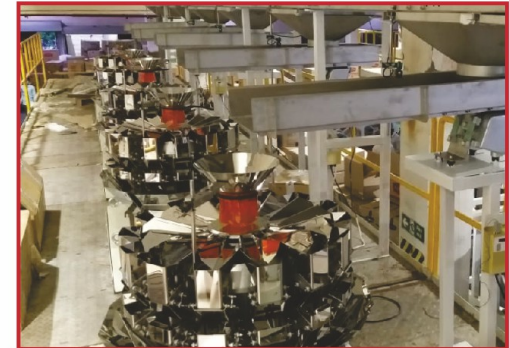

Cross Vibratory Feeder

FINISHED GOODS



Pro Runner Carton Vertical Lift System



Bin Lifter & Tilter Upto 300 kg/Bin



Spiral Conveyor from Top Floor to
Ground CB Transfer



BUCKET ELEVATOR DISTRIBUTION SYSTEM



Advantages

- Only 1 Motor... Power Saving!
- Multiple Drops
- Multiple Configurations
- Combination of Vertical & Horizontal Conveying
- Easy to Clean at Ground Level
- Fully Modular

Best For

- Nuts
- Convenience Snack Food Products
- Confectionery Items
- Wrapped Candies
- High Bulk Density Food Products

VIBRATORY DISTRIBUTION SYSTEM



Advantages

- No Moving Parts
- Multiple Drops
- 100% Sanitary Rigid Construction
- Large Carrying Capacity... Good for Low Density Products
- Noiseless System Operation
- Fully Modular

Best For

- Chips
- Wafers
- Extruded Snacks
- Slurry Coated Snacks
- Low Bulk Density Food Products



POP CORN LINE

Automatic Savory & Caramelized Popcorn Line

1. No oil used for popping corn kernels
2. Variable capacities
3. Consistent product quality
4. Fully automatic
5. Easy maintenance

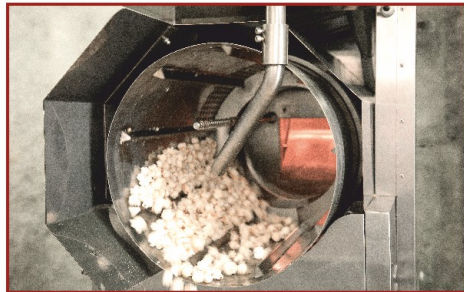

POP CHIPS POPPER

Automatic Pop chips Line

1. Unmatched Precision and Control
2. Enhanced Productivity
3. Popping through high heat and pressure
4. Versatility and Customization
5. Reliable and Durable Performance

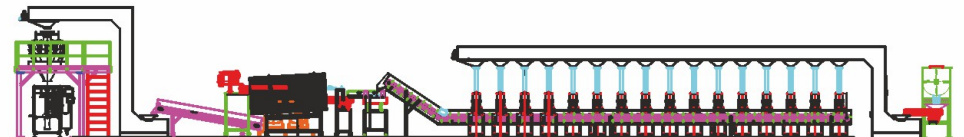
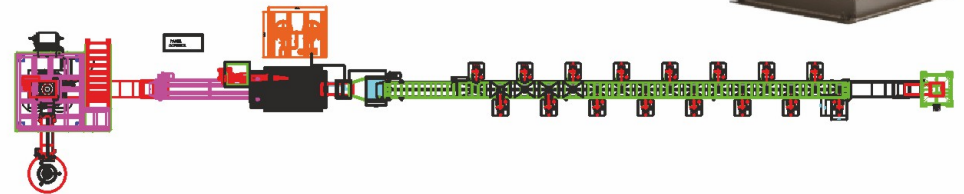

POWDER HANDLING SOLUTIONS

Flexible Screw Conveyor

1. Suitable for Powder, Salt, Spices, Sugar etc
2. Flexibility in design
3. Quick and Easy Commissioning
4. Dust Free
5. Gentle handling
6. Low in Maintenance



Tubular Drag Conveyor

1. Operational at all angles including loop system
2. Completely Enclosed, Dust Free, No Contamination Possibility
3. Can handle all type of Product as for Solid, Wet, Hygroscopic etc
4. Complete Transfer
5. Low in Noise, Maintenance
6. Dust Free



Aero Mechanical Conveyor

1. Suitable for all type of powder, granules
2. Complete Total transfer
3. No Dust Collection System
4. Low Power Consumption
5. Complete Enclosed
6. Operational at multiple angles



Bulk Bag Discharge System

1. Volume & Weigh Based both options.
2. Suitable for all Bulk Bag types and sizes
3. Quick and Easy Commissioning
4. Dust Free
5. Bag tensioner
6. Massagers for complete discharge





DÖINGHAUS

Customized
Ultrasonic Cutting Machines
for Indian Confectionery

We have the right solution!



**Industrial cleaning system
for multihead weigher components**

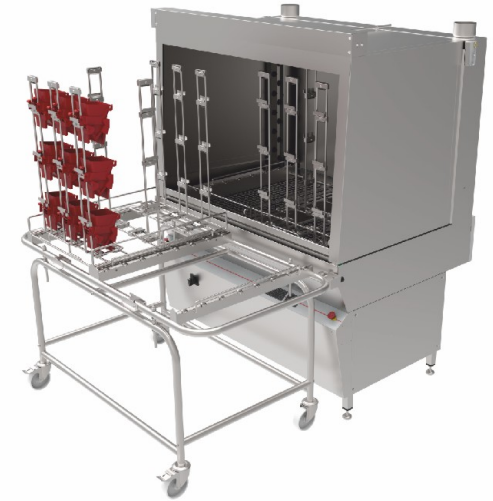

AUTOMATIC FORMING MACHINES



DREMAX[®]

Versatile Super Slicer (Dicer)

Vegetable



Fruits



Meat



Ph. No. : +91-981-837-7111, 851-007-7834

Graphical representation only for reference

Represented lines are subject to change as per latest design | 22

OUR GLOBAL PRINCIPALS

SYSPAL™

Single Bin Solution....

- ✓ The full production solution for 200L & 300L Eurobins
- ✓ Less manual handling with all processes within one bin
- ✓ Increased productivity
- ✓ Less product waste
- ✓ Improved product quality



WEIGH



MIX



TIP



WASH



STORE



KMG System Ltd.

- ✓ Europe's Largest Seasoning and Distribution System Manufacture
- ✓ Patented KMG FlowWeigher™ and Loss in Weight
- ✓ Industry leading seasoning performance
- ✓ Technical expertise: we develop smart, safe, hygienic solutions
- ✓ Balanced pivoting gate or gateless distribution system
- ✓ Complete in-house manufacture
- ✓ In house team of PLC and screen programmers



- ✓ Modular in construction
- ✓ Hygienic design
- ✓ Designed with recirculation



spiroflow

- ✓ Flexible Screw Conveyors
- ✓ Aero Mechanical Conveyors
- ✓ Cableflow Cable Drag Conveyors





Fabcon India flying high with National Pride.

#makeinindia #makelocal #goglobal #sustainablesnacksolutions #indianfoodprocessingsolutions
#dedicatedteam #growwithcustomer #continuousdevelopment

Fabcon™ INDIA 

HO & Factory : Plot No. 73, Ecotech XII, Greater Noida (Delhi-NCR), INDIA
Ph. No.: +91-981-837-7111, 851-007-7834
e-mail : md@fabcon.co.in, sales.mgr@fabcon.co.in
Website : www.fabcon-india.com

We can provide other related equipments as well like:

• Extruder • VFFS • Kettle Chips Setup etc.

MSME
सूक्ष्म, लघु एवं मध्यम उद्यम
MICRO, SMALL & MEDIUM ENTERPRISES



Website



G.MAP